

Airbus Helicopter Aerolite Medical Interior

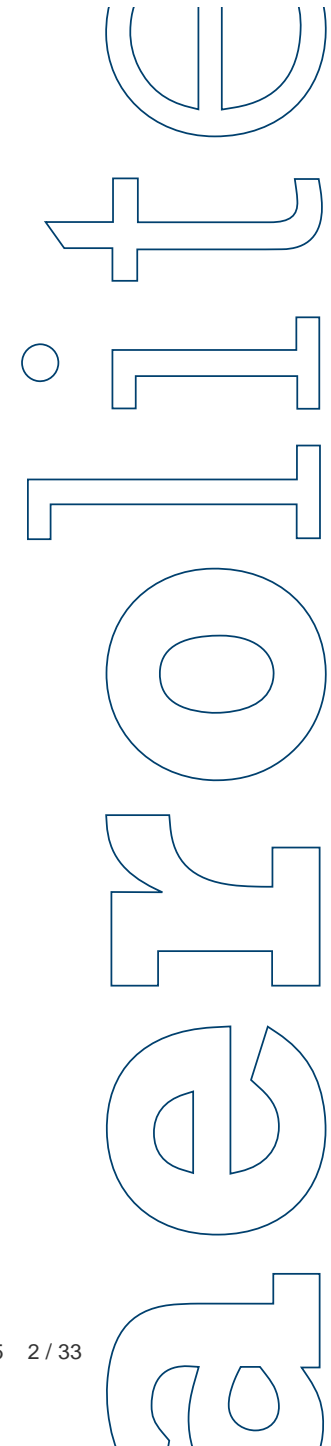

Summary

1. **Aerolite Presentation**
2. **EMS Equipment Airbus Fleet**
3. **Presentation EMS Kit EC135T2/T3**



Aerolite and the EMS industry, a long story....

- 1995 Aerolite Max Bucher AG, established by Max Bucher**
- 1997 Production facility in Ennetbürgen, Switzerland**
- 2004 Delivery of 100th EC135 EMS Interior**
- 2006 Aerolite America LLC in South Carolina, USA**
- 2007 Aerolite GmbH Donauwörth Germany**
- 2008 Aerolite Completion Center in Dübendorf, Switzerland**
- 2014 Roland Hengartner appointed as CEO**

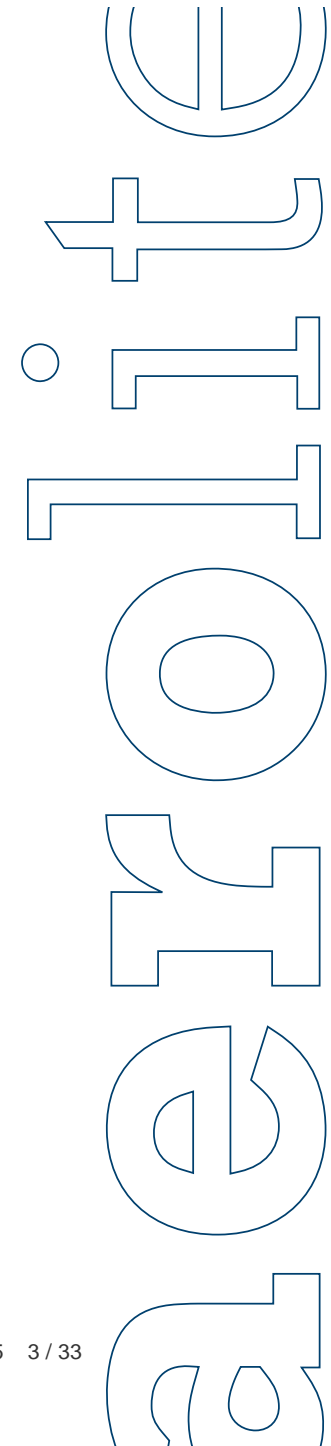

Aerolite an unique reference in the EMS industry...

- For over 20 years a strong partnership with AHD as EMS kit supplier for EC135 & EC145
- European EMS market leader : more than 550 rotorcraft in operation equipped with Aerolite EMS kits
- New EMS Kit developed for EC145T2 and EC135T3
- New equipment developed in close relation with EMS operators: e.g. roll-in stretcher for EC145C2/T2, PTU for A380/B747, etc.
- Programme available for the retrofit of in-service rotorcraft from VIP/Corporate configuration to EMS configuration, (over 10 rotorcraft retrofitted in 2014)
- Aerolite reputation in terms of quality and reliability will bring an added value to rotorcraft in the case of resale

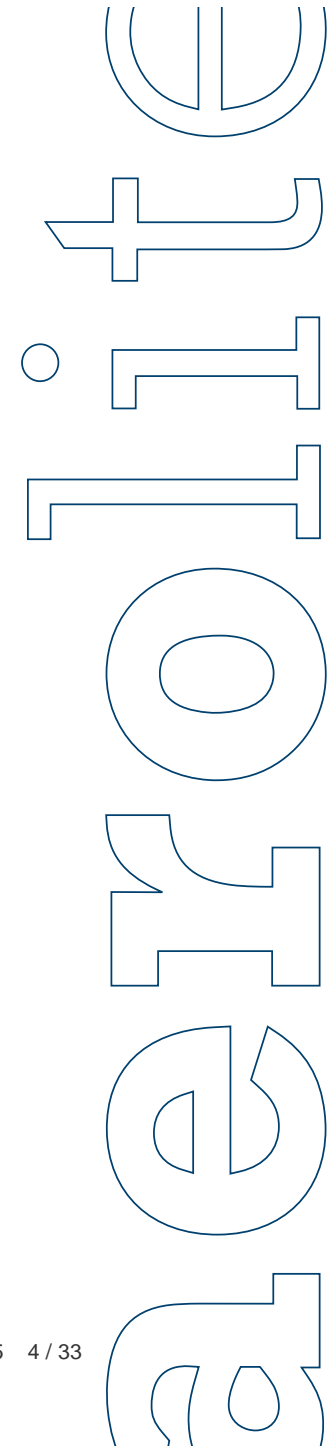

Aerolite, world wide recognition in the EMS community...

- Aerolite kits fly on each continent in the world: Europe, Russia, USA, Canada, Africa, South America, Asia and Australia
- Aerolite kits is a standard for the 24/7h safety organization in Europe: UK, Switzerland, Scandinavia, France, etc.
- Major European Customers:
 - BOND Air Services
 - REGA, Air Zermatt
 - DRF, ADAC
 - Scandinavian Medicopter
 - NOLAS
 - INAER France, Mont Blanc Helicopter, SAF, HDF
 - INAER Italy & INAER Spain
 - LPR Poland

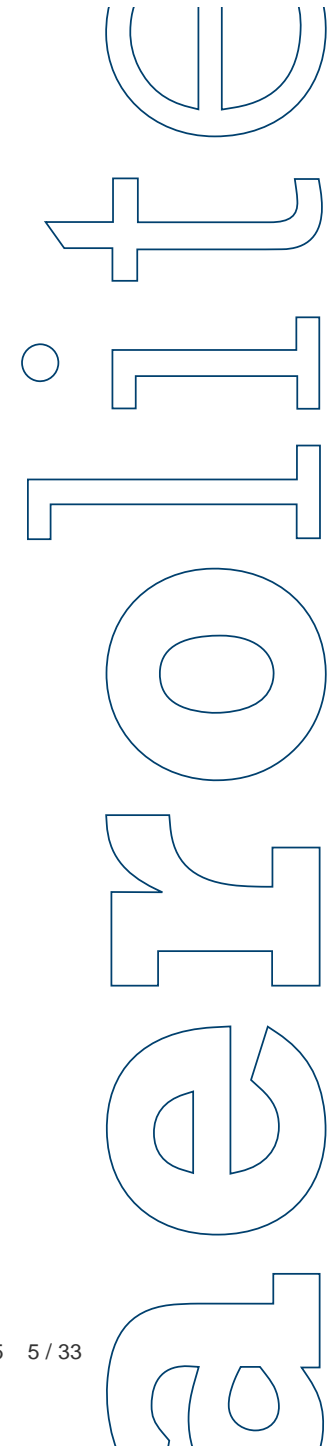

Aerolite a company solely dedicated to the EMS solutions....

- **Yearly production of EMS kits > 30**
- **90 employees: including engineers (designer, certification & documentation), sheet metal workers, oxygen system specialist's and aircraft mechanics**
- **Aerolite approvals: EASA Part 21 DOA & POA, EASA Part 145 MOA, EN 9100, ISO 9001 / 13485**
- **Offering a customized answer to EMS operator's requirements by handling an average of 75 engineering projects per year (in 2014: 13 new or major changes to STC and 62 minor changes & various validations)**
- **Innovating modular EMS equipment for EC135T3 covering diverse cabin configurations, stretcher systems, oxygen/electrical systems under a single STC (in EASA approval process)**

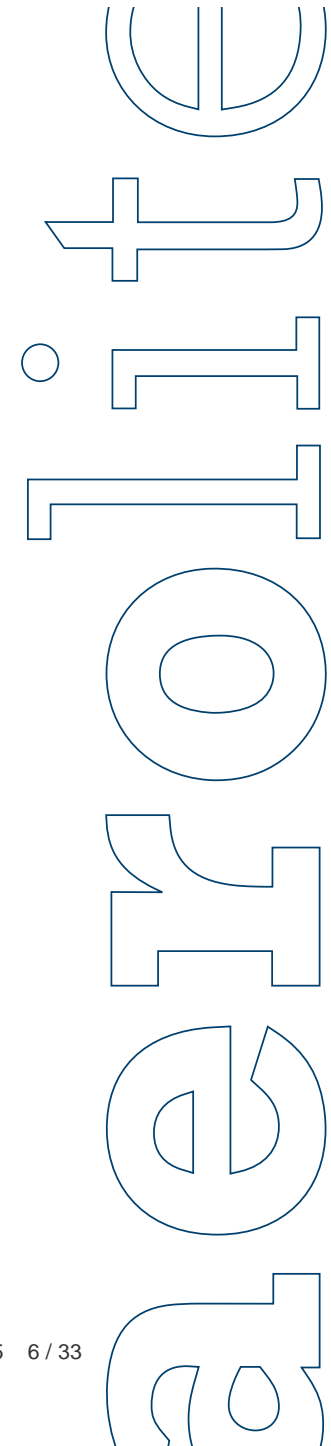

EC135



aerolite

@Aerolite Max Bucher AG

October 2015 7 / 33

aerolite

EC135T3 – Cabin Layout

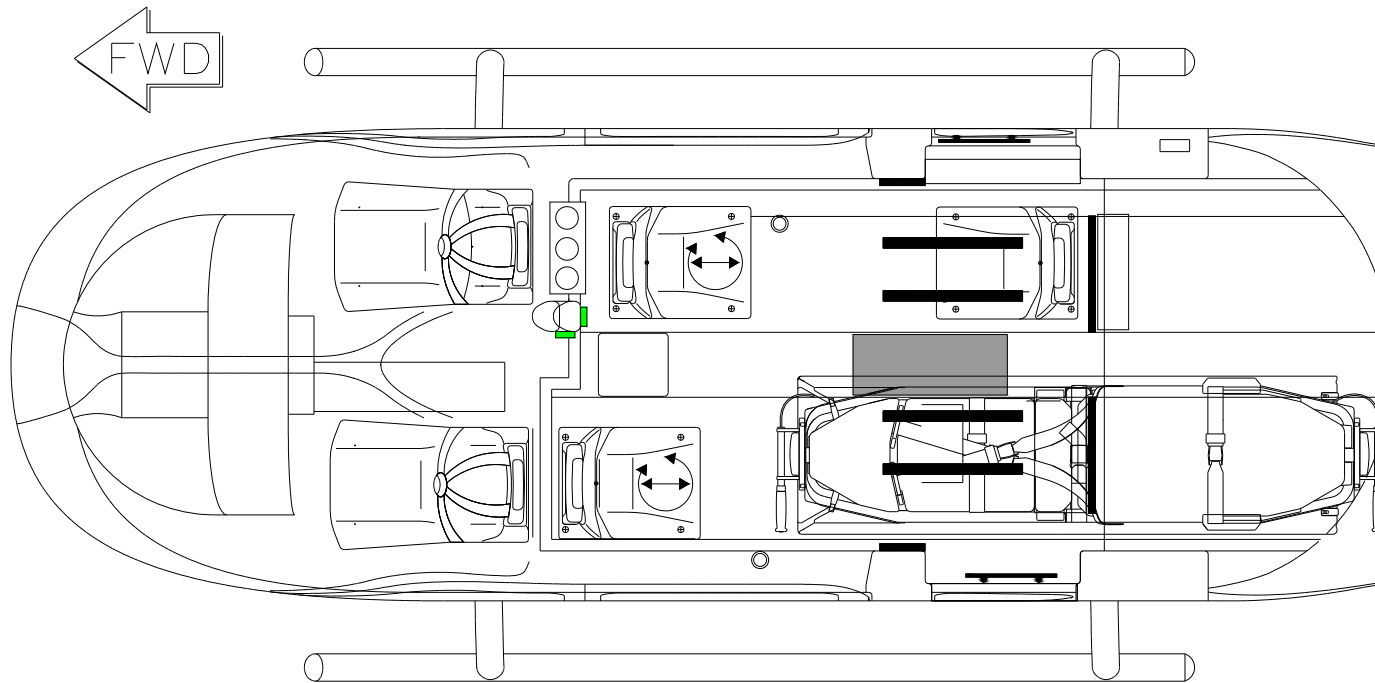

EMS LAYOUT: Configuration 1

EC135T3 – Cabin Layout

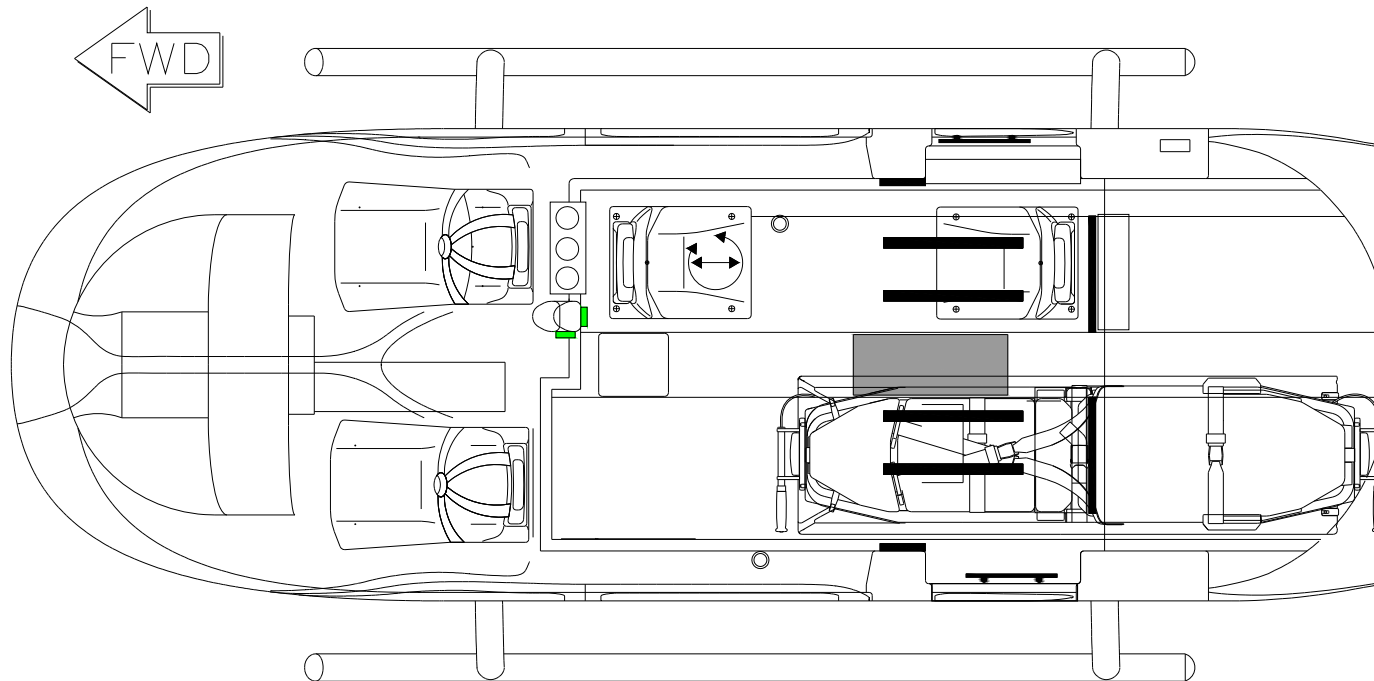

EMS LAYOUT: Configuration 2

EC135T3 – Cabin Layout

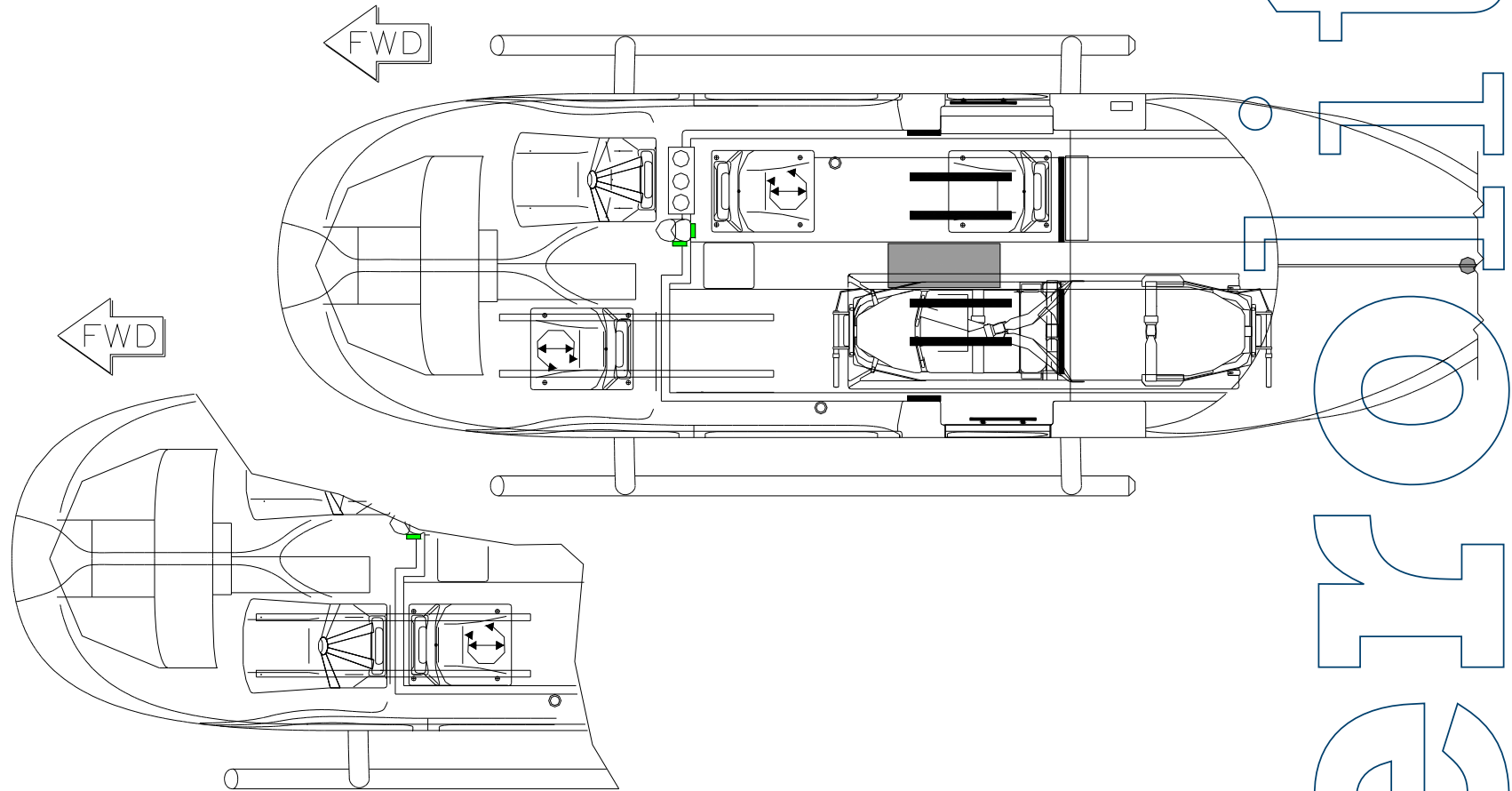

EMS LAYOUT: Configuration 3

EC135T3 – Floor protection



- Light weight aluminum floor panel
- Easily removable
- Four full length seat tracks
- Integrated go around liquid collection channel with drain system
- Weight : 29.0kg

Aerolite Integral – Medical Floor

aerolite

@Aerolite Max Bucher AG

October 2015 12 / 33

aerolite

EC135T3 – Floor protection



**Lining floor
Weight : 13.0kg**

Floor Protection

aerolite

@Aerolite Max Bucher AG

October 2015 13 / 33

aerolite

EC135T3 – Cabin Layout



Installation with AEL Integral floor:

Weight : 3 seats configuration 130.0kg
2 seats(RH side) configuration 119.0kg

(can be adapted to Airbus Multi Function Floor with relocation of the oxygen bottle rack – behind aft mid seat cabin – Major change to STC)

EMS Layouts : 1 Patient / 2 or 3 Pax

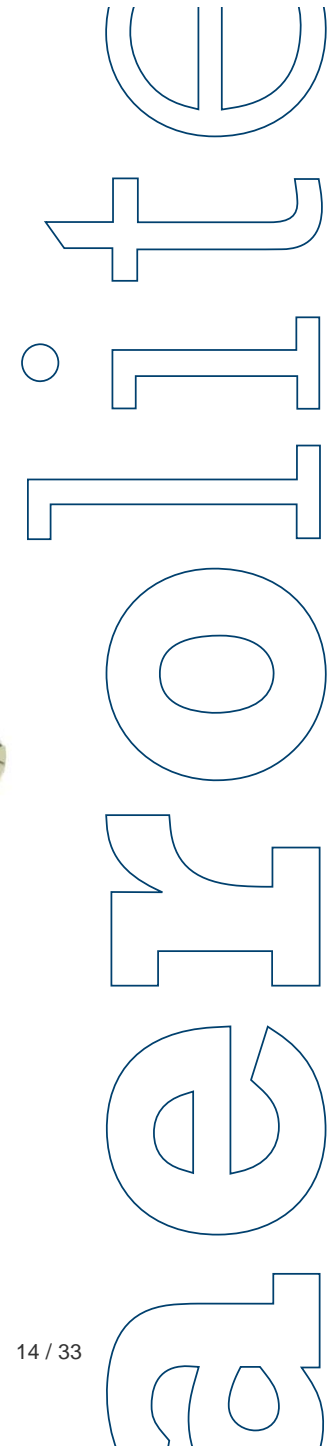

EC135T3 – Cabin Layout

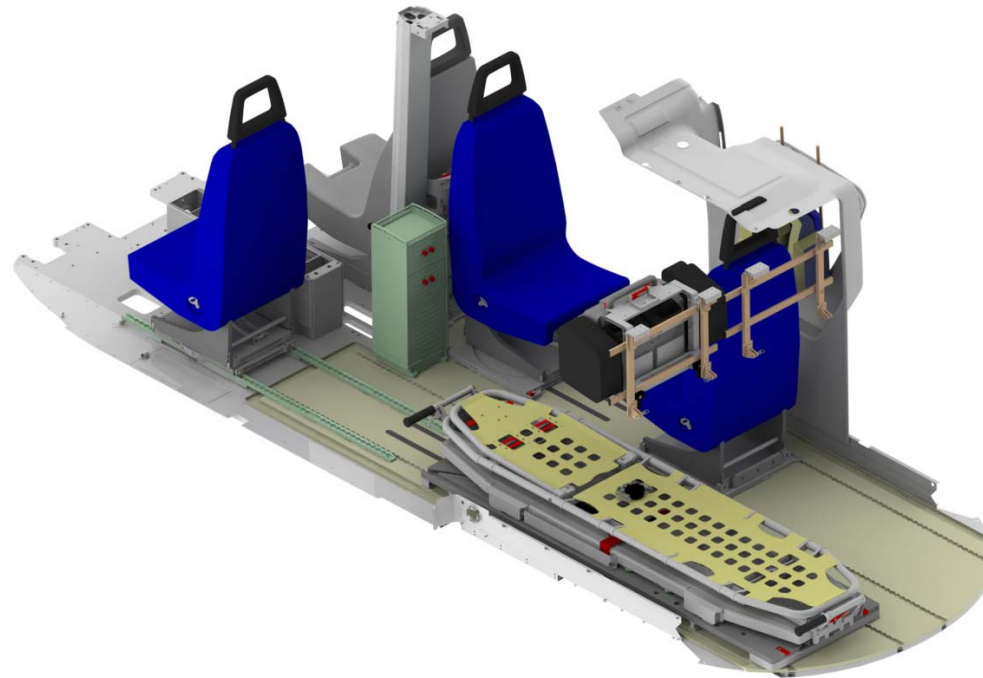

Installation with AEL Integral floor : weight 140.0kg
(co-pilot seat can be removed – flights controls co-pilot side must be removed)

EMS Layouts : 1 Patient / 2 Pax (+EMS reversible seat)

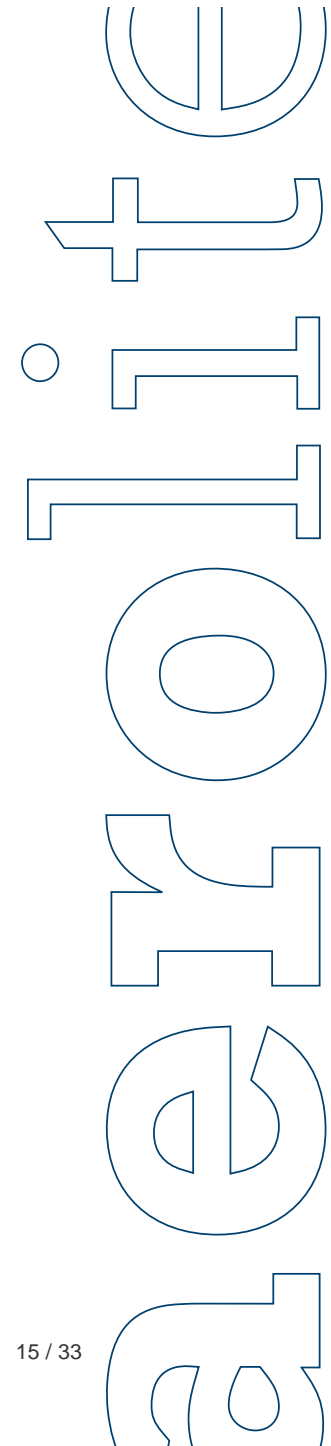

EC135T3 – Cabin Layout



**Installation with Airbus Multi Mission Floor: weight 62.0kg
(Spineboard not included)**

EMS Layouts : 1 Patient / 2 Pax

EC135T3 Kit Description – Cabin Layout



Installation with Airbus Multi Mission Floor:

Weight : 3 seats configuration 93.0kg
2 seats(RH side) configuration 82.0kg

EMS Layouts : 1 Patient / 2 or 3 Pax

EC135T3 Kit Description – Cabin Layout

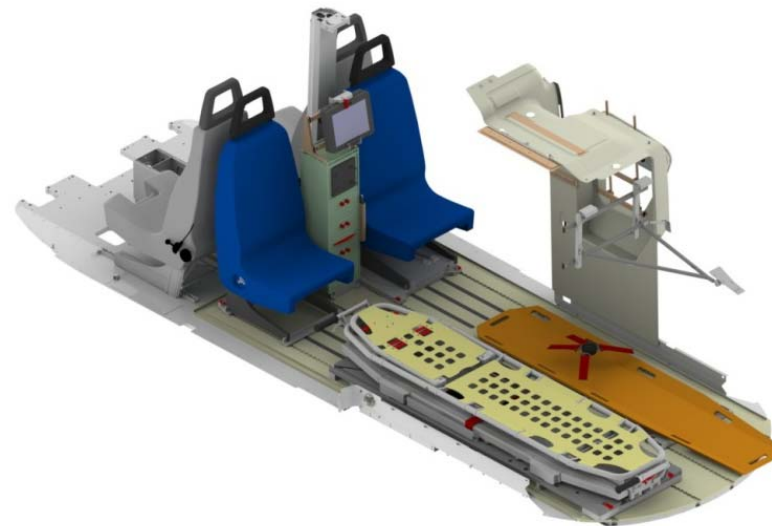
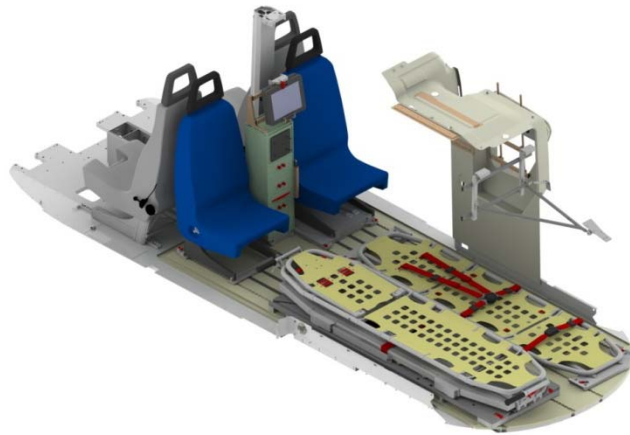

EMS Layouts : 2 Patients / 2 Pax

aerolite

@Aerolite Max Bucher AG

October 2015 18 / 33

aerolite

EC135 – Stretcher System



**Cirrus Stretcher:
Dimension 185x45
Weight 12.6kg**

Cirrus Stretcher

aerolite

aerolite

EC135 – Stretcher System



**Combi / scoop Stretcher:
Dimension 180x45
Weight 10.5kg**

Combi/scoop Stretcher type

aerolite

@Aerolite Max Bucher AG

October 2015 20 / 33

aerolite

EC135 – Stretcher System



Stretcher side and rear loading

EC135 – Stretcher System



Stretcher side and rear loading

EC135T3 – Cabin view



NOLAS

aerolite

aerolite

EC135T3 – Cabin view



Bond

aerolite

ER
J
T
T
O
R
T
E
S
E

EC135T2 – Cabin view



DRF

aerolite

aerolite

EC135T2 – Cabin view



HIRATA

aerolite

@Aerolite Max Bucher AG

October 2015 26 / 33

ER
t
i
T
O
T
E
e

EC135T3 – Cabin view



AIUT Alpin



aerolite

aerolite

EC135T2/T3 – Equipment Rails



Equipment rail AFT: 10.5kg/13.0kg payload / ea
(6.5kg /ea with oxy rack installed)



Equipment rail Ceiling: 8.0kg/10.0kg payload / ea



Equipment rail (Wdw): 10.0kg payload / ea



Door frame: 10.0kg payload / ea

Equipment Rails payload

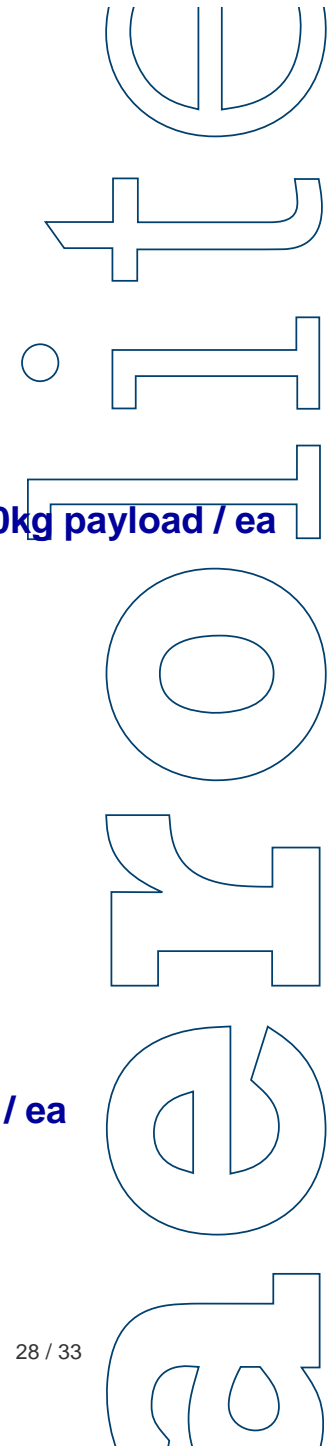

EC135T2/T3 – Equipment Rails

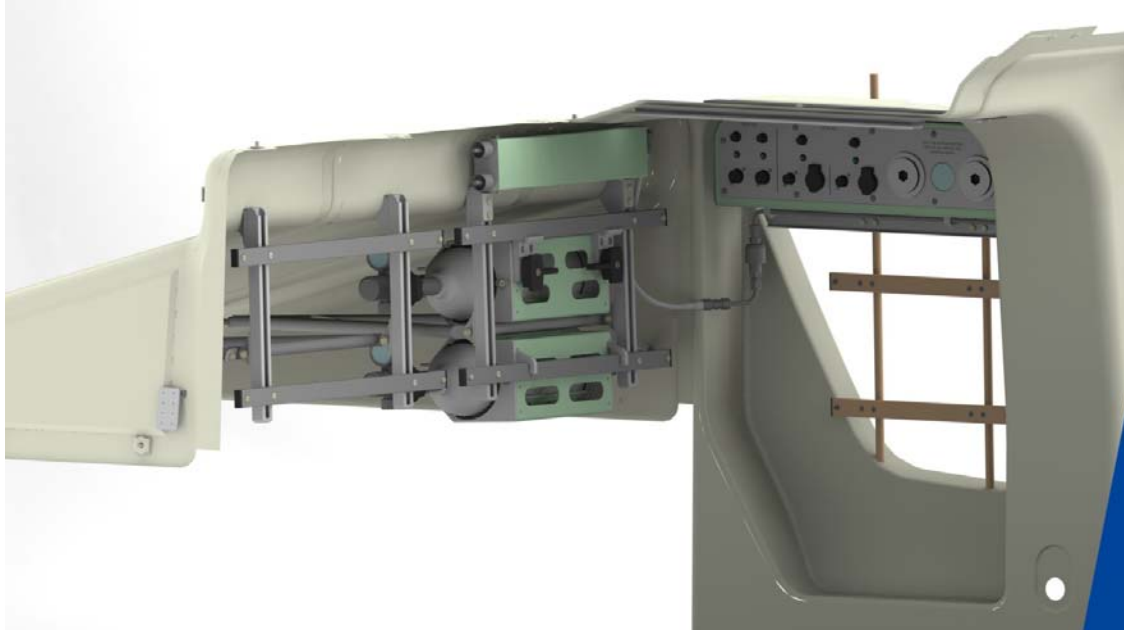

- Equipment rail (Wdw) : 10.0kg payload / ea
- Equipment rail AFT : 10.5kg payload / ea (6.5kg /ea with oxy rack)
- Equipment rail Ceiling : 10.0kg payload / ea
- Oxygen cylinder : 4.0kg payload / ea

Equipment Rails EC135T3

EC135T2/T3 – Cabinet

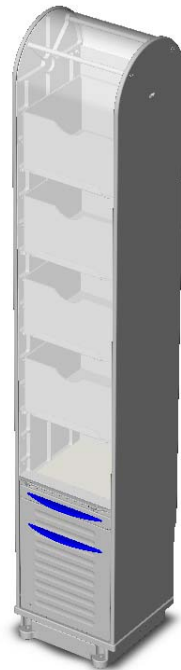

Cabinet Stowage Capacity: 10.0kg

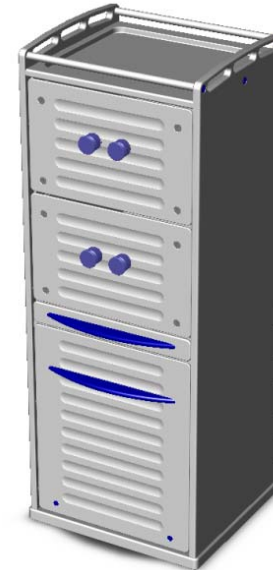

HH Cabinet stowage Capacity: 7.0kg

Stowage Capacity Cabinet

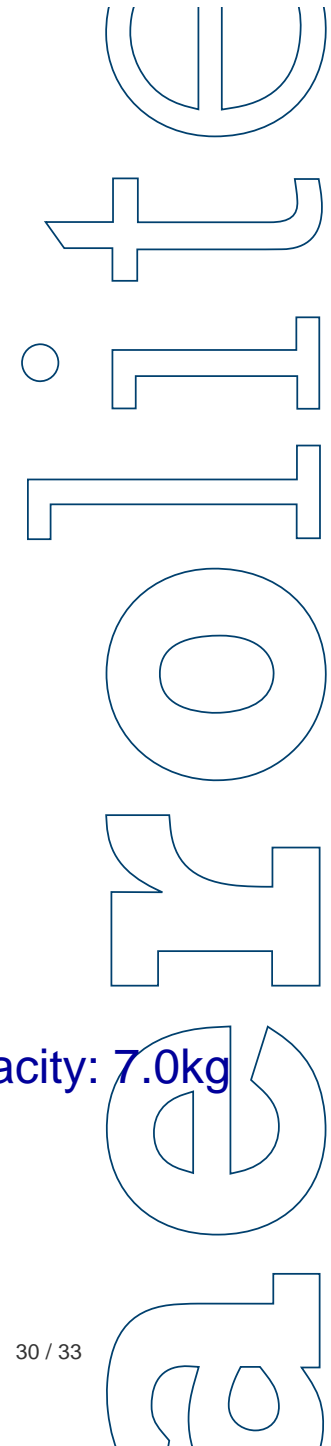

EC135T2/T3 – Supply panel



Electrical supply

Basic

- 24/28VDC
- 12/14VDC

Optional

- 230VAC (option)
- Shore Power System (option)

Oxygen outlets type

- AGA type
- DKD
- Dräger
- Beacon Meades



Supply Panel (Oxygen/Electrical)

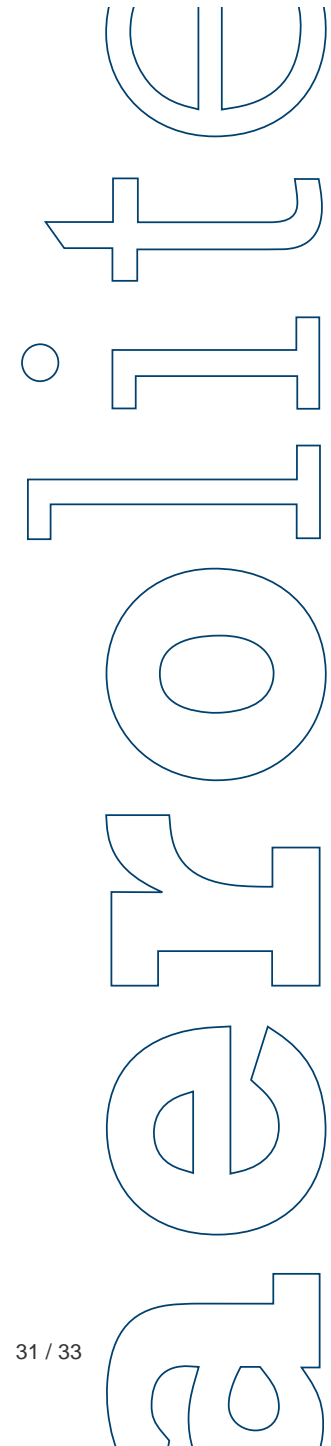

EC135T2/T3 – Lighting system



EMS Lighting Electrical:

- Main Cabin Light
- Dome light in cargo compartment (with 5mn temporary)

Thank you for your attention

Please contact us for details!

**Aerolite Max Bucher AG | Amühlestrasse 10
6373 Ennetbürgen | Switzerland | Phone +41 41 624 53 53**

**Completion Center | Ueberlandstrasse 255
8600 Dübendorf | Switzerland | Phone +41 44 822 93 33**

**Aerolite America LLC | 1012 Market Street, Suite 305
Fort Mill | SC 29708 | USA | Phone +1 803 802 44 42**

aerolite

@Aerolite Max Bucher AG

October 2015 33 / 33

AEROLITE